

Blue Cross and Blue Shield of Texas (BCBSTX)

835 Electronic Funds Transfer (EFT)
Standard Companion Guide

Refers to the Implementation Guides
Based on ASC X12 version 005010

Version 1.3

April 2018

Disclosure Statement

This material contains confidential and proprietary information. Unauthorized use or disclosure of the information is strictly prohibited. The information in this document is intended for providers who have established a provider record with Blue Cross and Blue Shield of Texas (BCBSTX) and electronic trading partner use only. BCBSTX may make improvements and/or changes in the product and/or program described in this publication at any time. Revisions may be made periodically and updated versions of this document will be published accordingly.

Disclaimer

The information in this document is believed to be correct at the time of publication and is provided by BCBSTX for awareness, and educational purposes only. This material does not purport to provide legal advice. The information provided here is for reference use only and does not constitute the rendering of legal, financial, or other professional advice or recommendations by BCBSTX. If legal advice is required, the reader should consult with an attorney.

Preface

The Affordable Care Act (ACA) mandates implementation of Administrative Simplification operating rules to promote greater uniformity in the exchange of electronic health care data. The Committee on Operating Rules for Information Exchange (CORE) is part of the Council for Affordable Quality Healthcare (CAQH) initiative. CAQH CORE has authored operating rules to be implemented in phases for HIPAA-standard electronic data interchange (EDI) transactions, including the Health care Claim Payment/Advice (835).

This Companion Guide to the v5010 ASC X12N Implementation Guides and associated errata adopted under the Health Insurance Portability and Accountability Act (HIPAA) clarifies and specifies the data content when exchanging electronically with Texas. Transmissions based on this companion guide, used in tandem with the v5010 ASC X12N Implementation Guides, are compliant with both ASC X12 syntax and those guides. This companion guide is intended to convey information that is within the framework of the ASC X12N Implementation Guides adopted for use under HIPAA. The BCBSTX 835 EFT Companion Guide is not intended to convey information that in any way exceeds the requirements or usages of data expressed in the v5010 ASC X12N Implementation Guides.

Table of Contents	
SECTION 1: INTRODUCTION	5
1.1 – Scope	5
1.2 – Overview	5
1.3 – References	5
1.4 – Additional Information	5
SECTION 2: GETTING STARTED	6, 7
2.1 – Working with BCBSTX	6
2.2 – Trading Partner Registration	6
2.2.1 – Electronic Enrollment Process	6
2.2.2 – Paper Enrollment Process	6
2.3 – Certification and Testing Overview	7
2.3.1 – Availability of Funds	7
2.3.2 – Late/Missing EFT Resolution Procedure	7
SECTION 3: CONNECTIVITY WITH BCBSTX/COMMUNICATIONS	8, 9
3.1 – Process Flow	8
3.2 – Transmission Administrative Procedure	8
3.3 – Re-transmission Procedure	9
SECTION 4: CONTACT INFORMATION	10
4.1 – EDI Customer Service	10
4.2 – EDI Technical Assistance	10
4.3 – Provider Service Number	10
4.4 – Applicable Websites	10
SECTION 5: CONTROL SEGMENTS AND ENVELOPES	11,12
5.1 – ISA-IEA	11
5.1.1 – Delimiters/Separators	11
5.2 – GS-GE	12
SECTION 6: BCBSTX-SPECIFIC BUSINESS RULES AND LIMITATIONS	13
SECTION 7: ACKNOWLEDGEMENTS AND/OR REPORTS	13
SECTION 8: TRADING PARTNER AGREEMENTS	13
APPENDICES	14
A1 – Additional Resources	14
A2 – Change Summary	14

Section 1: Introduction

1.1 Scope

The HIPAA transaction implementation guides for Electronic Data Interchange (EDI) transactions are called Technical Reports, Type 3 (TR3s). These TR3s provide guidelines for submitting and receiving HIPAA-standard EDI transactions. The TR3s require transmitters and receivers to make certain determinations. The BCBSTX 835 EFT Companion Guide does not replace the HIPAA ASC X12N TR3s, nor does it attempt to amend any of the information therein. It does not impose any additional obligations that are not permitted to be imposed by the HIPAA standards for electronic transactions. If inconsistencies exist between the terms of this companion guide and the TR3(s), the relevant TR3(s) will govern with respect to HIPAA edits. The BCBSTX Companion Guide will govern with respect to business edits.

The BCBSTX 835 EFT Companion Guide provides supplemental information to the Trading Partner Agreement (TPA) that exists between BCBSTX and its electronic trading partners. Trading partners should refer to their TPA for guidelines pertaining to any legal conditions surrounding implementation of EDI transactions and code sets. Information contained in this companion guide is not intended to amend, revoke, contradict, or otherwise alter the terms and conditions of the TPA. If there is an inconsistency with the terms of this guide and the terms of the TPA, the terms of the TPA shall govern.

1.2 Overview

EFT is the automated transfer of claims payments from the health plan to the provider's designated financial institution. Section 1104 of ACA adds EFT to the list of HIPAA-standard EDI transactions, as mandated by the Healthcare EFT Standards (CCD+ and X12 v5010 835 TR3 TRN Segment).

This companion guide contains assumptions, conventions, determinations or data specifications that are related to EFT and may be unique to BCBSTX. This document also provides information on BCBSTX-specific code pertinent to BCBSTX business processes and situations which are within the parameters of HIPAA. Readers of the companion guide should be familiar with the HIPAA ASC X12 TR3s, their structure and content.

1.3 References

Entities that conduct HIPAA-standard transactions are responsible for obtaining and following EDI transaction standards specified within the current HIPAA-mandated ASC X12 5010 TR3s.

The Washington Publishing Company (WPC) is an independent publisher of technical reports recognized by the Centers for Medicare & Medicaid Services (CMS) as the industry standard. To purchase TR3s, visit the WPC website at wpc-edi.com.

1.4 Additional Information

The reader of this companion guide is assumed to be a provider who has established a provider record with BCBSTX and/or the provider's designated billing agent (billing service or clearinghouse) that transmits to or receives electronic data from BCBSTX. For the purposes of this document, the reader may be referred to as a trading partner or a provider.

In addition to the 835 EFT, trading partners are encouraged to conduct other HIPAA-standard EDI transactions when conducting business with BCBSTX. Before, during and after the claim submission process, electronic transactions help maximize administrative efficiencies, reduce unnecessary paper waste, decrease the need to conduct time-consuming telephone transactions, increase security of BCBSTX members' protected health information and promote greater accuracy with faster completion of each transaction. Additional information of the variety of EDI transactions available and/or supported by BCBSTX, refer to the [Claims and Eligibility/Electronic Commerce section](#) of the BCBSTX Provider website at bcbstx.com/provider.

Section 2: Getting Started

2.1 Working with BCBSTX

Commercial and government programs* providers who have established a provider record with BCBSTX are strongly encouraged to participate with the Plan's EFT under the Terms and Conditions set forth within the EFT Authorization Agreement. Providers also must use their best efforts to participate with the Plan's Electronic Remittance Advice (ERA) as described on the ERA Enrollment Form. Additional information on EFT and ERA is available in the [Claims and Eligibility/EFT and ERA section](#) of our website at bcbstx.com/provider.

*Government programs products include Blue Cross Medicare Advantage (PPO)SM (MA PPO) and Blue Cross Medicare Advantage (HMO)SM (MA HMO).

2.2 Trading Partner Registration

Providers are strongly encouraged to enroll for EFT electronically. Agreement with the EFT Authorization Agreement Terms and Conditions is required.

Note: If enrolled for the 835 EFT and ERA, the provider must contact their financial institution to arrange for the delivery of the CORE-required Minimum CCD+ data elements needed for reassociation of the payment and the 835 ERA. Reassociation is a process that supports matching of payments with claim data for posting to your patient accounts. A sample letter you can customize and send to your bank is available in the CORE section of the CAQH website at <http://www.caqh.org/benefits.php>. (Go to Mandated Operating Rules then select EFT and ERA. Scroll down to Implementation Resources section and look for the [Sample Provider EFT Reassociation Data Request Letter](#) link.) This document includes instructions to assist you with requesting delivery of the data, as well as a glossary of key terms.

2.2.1 Electronic Enrollment Process

Providers who have established a provider record with BCBSTX and are registered with AvailityTM may enroll online for EFT through the Availity Provider portal at availability.com.* Please note that this function must be performed by the provider's Availity Administrator. For enrollment status and assistance with other enrollment-related concerns, contact BCBSTX Electronic Commerce Services at ecommerceservices@bcbstx.com or 800-746-4614.

*There is no cost to register or use the Availity Provider portal. Details are available at availability.com.

2.2.2 Paper Enrollment Process

The EFT Authorization Agreement is available in the [Education & Reference/Forms section](#) of our website at bcbstx.com/provider. This EFT Authorization Agreement must be fully completed, signed and returned via fax to BCBSTX Electronic Commerce Services at 312-946-3500.

Either a voided check from the provider's account or a letter from the financial institution on financial institution letterhead specifying the provider's name, the account and financial institution routing/ABA number must be included with the signed EFT Authorization Agreement. For enrollment status and assistance with other enrollment-related concerns, contact BCBSTX Electronic Commerce Services at ecommerceservices@bcbstx.com or 800-746-4614.

2.3 Certification and Testing Overview

Upon completion of the enrollment process, the trading partner will receive a letter from BCBSTX to acknowledge and approve the request for EFT. The letter also provides notification that BCBSTX will conduct prenote testing with the designated financial institution, along with the date EFT payments will be implemented, pending successful completion of prenote testing.

2.3.1 Availability of Funds

In general, funds will be transferred to your financial institution within two banking days, after the claim is finalized, depending on your payment schedule. EFT payment dates may be affected by banking and corporate holidays. Refer to the [Holiday Schedule Reminders](#) in the Claims and Eligibility/Electronic Commerce section of our website at bcbstx.com/provider for details.

Use the following guide to identify the payment type:

If the check trace number begins with:	The payment type is:	Example (TRN02):
C	Commercial	C16123E12345670
F	FEP Dental	F16123E12345670
H	HMO Capitation	H16123E12345670
T	BCBSTX Medicaid	T16123E12345670
M	Medicare Advantage	M16123E12345670

2.3.2 Late/Missing EFT Resolution Procedure

Late or missing is defined as a maximum elapsed time of four business days.

For commercial claims, the following process describes how late/missing EFTs are identified and resolved by BCBSTX:

1. For commercial claims, when a provider determines they are missing an EFT, the provider contacts BCBSTX Electronic Commerce Services at ecommerceservices@bcbsxx.com or 800-746-4614. An inquiry is generated and routed to the BCBSTX 835 team for research resolution.
2. BCBSTX researches to determine if EFT is set up for the provider. If not, the provider is advised on how to enroll. If enrollment is confirmed, BCBSTX checks internal systems to determine if the EFT was issued and to verify status, funded or returned.
3. If returned, BCBSTX checks the return code and advises the provider accordingly.
 - If returned with a reissue code, EFT data can be updated and the failed EFT is auto-reissued.
 - If the EFT reason code is not a reissue code, a paper check is requested and the provider is advised of the status.

For government programs claims, additional information may be obtained from Customer Service at the following numbers:

Blue Cross Medicare AdvantageSM (MA HMO and MA PPO)
Individual: 877-774-8592
Group: 877-299-1008

Section 3: Connectivity with BCBSTX/Communications

This section is for informational purposes only to provide an overview of the transmission of 835 EFT data between BCBSTX and the financial institution, as well as transmission/re-transmission procedures and communication protocol specifications.

3.1 Process Flow

Below is a diagram that outlines the general process flow for the 835 EFT transaction to the financial institution, with the response 997/824/827 transactions from the financial institution back to BCBSTX.

The 997 is sent per the agreement between BCBSTX and the financial institution. The 824 is the daily file that BCBSTX receives whenever BCBSTX's bank receives an 835 EFT file from BCBSTX. The translated 824 file is used to confirm accepted or acknowledged status. The 827 file is a collection of EFT payments that have been rejected or corrected by the bank for various reasons, such as incorrect/invalid bank account number, closed account, etc. The translated 827 file is used to identify rejected status.

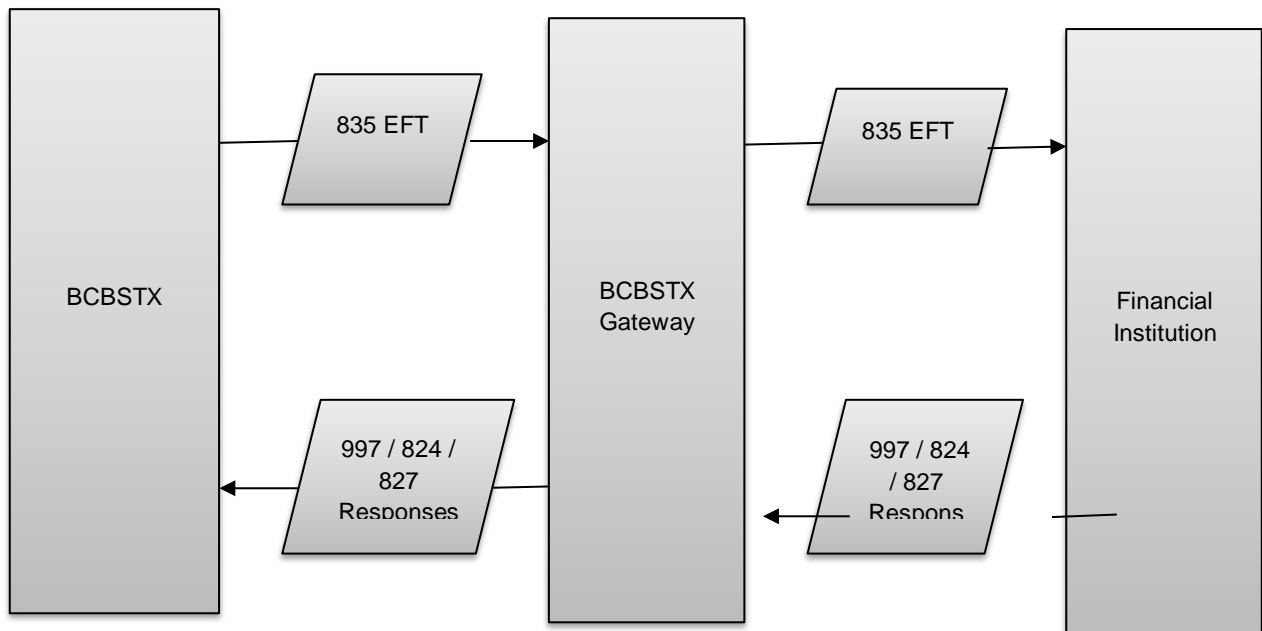

3.2 Transmission Administrative Procedure

BCBSTX (the payer) will send one transmission to the bank each day. This file will contain the following:

- One interchange (ISA-IEA) per transmission
- One functional group (GS-GE) per transmission
- Multiple transaction set (ST-SE) per transmission

Refer to the TR3(s) for terminology clarification and additional information.

3.3 Re-transmission Procedure

The following notifications will be sent by the financial Institution to BCBSTX if a transmission is unable to be completed for the outbound 835 EFT:

- **997 Functional Acknowledgement Transaction**

If the transaction submission passes the ISA/IEA pre-screening above, it is then checked for ASC X12 syntax and HIPAA-compliance errors. When the compliance check is complete, a 997 will be sent to the trading partner informing them if the transaction has failed the compliance check. If multiple transaction sets (ST-SE) are sent within a functional group (GS-GE), the entire functional group (GS-GE) will be rejected with a 997 response.

The following notification will be sent by BCBSTX to the financial institution if a transmission is unable to be completed for the inbound 824/827:

- **997 Functional Acknowledgement Transaction**

If the transaction submission passes the ISA/IEA pre-screening above, it is then checked for ASC X12 syntax and HIPAA-compliance errors. When the compliance check is complete, a 997 will be sent to the trading partner informing them if the transaction has failed the compliance check. If multiple transaction sets (ST-SE) are sent within a functional group (GS-GE), the entire functional group (GS-GE) will be rejected with a 997 response.

Section 4: Contact Information

4.1 EDI Customer Service

For assistance with EFT enrollment questions and/or to report late/missing EFT payments for commercial claims, contact BCBSTX Electronic Commerce Services at ecommerceservices@bcbstx.com or 800-746-4614.

To report late/missing EFT payments for government programs claims, contact Customer Service, as follows:

Blue Cross Medicare Advantage (MA HMO and MA PPO)
Individual: 877-774-8592
Group: 877-299-1008

4.2 EDI Technical Assistance

For assistance with vendor (software vendor, billing service, clearinghouse) questions on specific transactions and/or technical assistance or support, contact the appropriate vendor.

4.3 Provider Service Number

Check the member's BCBSTX ID card for the appropriate number to call for assistance. As a reminder, electronic options are available for most types of transactions. If you do not have online access, you may contact BCBSTX Provider Customer Service at 800-451-0287 to use our automated interactive voice response (IVR) system.

For government programs claim-related questions, contact Customer Service, as follows:

Blue Cross Medicare Advantage (MA HMO and MA PPO)
Individual: 877-774-8592
Group: 877-299-1008

4.4 Applicable Websites

For additional information on:	Visit:
BCBSTX announcements, programs, initiatives, provider learning opportunities and related resources	bcbstx.com/provider
Purchasing TR3s	wpc-edi.com
CAQH CORE Phase III 835 EFT and ERA Operating Rules	caqh.org
Electronic EFT enrollment and other electronic transactions and services for BCBSTX providers	availability.com

Section 5: Control Segments and Envelopes

Control Segments apply to all transactions and include the ISA and GS Segments. These segments are part of every transmission structure. The parameters outlined below are applicable to the financial institution that has a direct connection with BCBSTX.

5.1 ISA-IEA

The Interchange Control Header (ISA06) Interchange Sender ID and (ISA08) Interchange Receiver ID are individually assigned to each trading partner (BCBSTX and the financial institution) per mutual agreement.

ANSI v5010 Requirements				
Field	Length	835 EFT Inquiry	824 Response	827 Response
ISA01	2	00	00	00
ISA02	10	(10 spaces)	(10 spaces)	(10 spaces)
ISA03	2	00	00	00
ISA04	10	(10 spaces)	(10 spaces)	(10 spaces)
ISA05	2	Interchange Sender ID Qualifier	Interchange Sender ID Qualifier	Interchange Sender ID Qualifier
ISA06	15	Interchange Sender ID	Interchange Sender ID	Interchange Sender ID
ISA07	2	Interchange Receiver ID Qualifier	Interchange Receiver ID Qualifier	Interchange Receiver ID Qualifier
ISA08	15	Interchange Receiver ID	Interchange Receiver ID	Interchange Receiver ID
ISA09	6	Date (yymmdd)	Date (yymmdd)	Date (yymmdd)
ISA10	4	Time (hhmm)	Time (hhmm)	Time (hhmm)
ISA11	1	Repetition separator (see table below)	Repetition separator (see table below)	Repetition separator (see table below)
ISA12	5	00501	00501	00501
ISA13	9	Control number	Control number	Control number
ISA14	1	0	0	0
ISA15	1	"P" must be used to indicate Production "T" must be used to indicate Test	"P" must be used to indicate Production "T" must be used to indicate Test	"P" must be used to indicate Production "T" must be used to indicate Test
ISA16	1	: = Composite separator	: = Composite separator	: = Composite separator

5.1.1 Delimiters/Separators

The delimiters/separators below cannot be used in a data element value elsewhere in the transaction. Use of these delimiters/separators within a data element could result in translation errors when the transaction is processed.

Delimiters/Separators		
Name	Character	Description
Asterisk	*	Data Element Separator
Carat	^	Repetition Separator
Colon	:	Component Element Separator
Tilde	~	Segment Terminator

5.2 GS-GE

The Group Control Header (GS02) Group Sender ID and (GS03) Group Receiver ID are individually assigned to each trading partner (BCBSTX and the financial institution) per mutual agreement.

ANSI v5010 Requirements				
GS01	2	HS	HB	HB
GS02	2/15	Application Sender's Code	Application Sender's Code	Application Sender's Code
GS03	2/15	Application Receiver's Code	Application Receiver's Code	Application Receiver's Code
GS04	8	Date (ccyymmdd)	Date (ccyymmdd)	Date (ccyymmdd)
GS05	4/8	Time (hhmm)	Time (hhmm)	Time (hhmm)
GS06	1/9	Group Control Number	Group Control Number	Group Control Number
GS07	1/2	X	X	X
GS08	1/12	Version/Release/Industry Identifier Code	Version/Release/Industry Identifier Code	Version/Release/Industry Identifier Code

Section 6: BCBSTX-specific Business Rules and Limitations

The section may be enhanced in the future to provide BCBSTX-specific data, business processes and situations which are within the parameters of HIPAA.

Section 7: Acknowledgements and/or Reports

BCBSTX processes the following ASCX12 HIPAA acknowledgements for EFT:

Acknowledgements	Description
ASC X12 997 005010X221A1 (HIPAA)	Functional Acknowledgement: A negative 997 is sent in case of compliance issues

(Refer to Section 3.3: Re-transmission Procedure for more information about 997s.)

Section 8: Trading Partner Agreements

This section contains general information concerning Trading Partner Agreements (TPAs).

An EDI Trading Partner is defined as any BCBSTX customer (provider, billing service, clearinghouse, software vendor, financial institution, etc.) that transmits to, or receives electronic data from BCBSTX.

Payers have EDI Trading Partner Agreements that accompany the standard implementation guide to ensure the integrity of the electronic transaction process. A Trading Partner Agreement is related to the electronic exchange of information, whether the agreement is an entity or a part of a larger agreement, between each party to the agreement. For example, a Trading Partner Agreement may specify among other things, the roles and responsibilities of each party to the agreement in conducting standard transactions.

Appendices

A1 Additional Resources

Additional information and other helpful resources are available in the [Claims and Eligibility/EFT and ERA section](#) of our website at bcbstx.com/provider.

A2 Change Summary

The Change Log below will be used to document revisions that are made after initial publication of the BCBSTX ANSI v5010 Companion Guides.

835 EFT Companion Guide Change Log				
Chapter	Section	Change Description	Date of Change	Version
Connectivity with BCBSTX/Communications	3.1	Removed outdated table and inserted brief paragraph to describe when funds normally are transferred to the provider's financial institution	April 16, 2014	1.1
Getting Started	2.1	Added reference to government programs with full product names	May 15, 2017	1.2
Getting Started	2.2	Revised language to emphasize electronic enrollment	May 15, 2017	1.2
Getting Started	2.2.1	Added: Reference to Primary Access Administrator; Electronic Commerce Center email address; registration info for Availity	May 15, 2017	
Getting Started	2.2.2	Removed mailing address for enrollment forms; added Electronic Commerce Center email address	May 15, 2017	1.2
Getting Started	2.3.1	Added reference to government programs and chart/guide with check trace number information to identify payment type	May 15, 2017	1.2
Getting Started	2.3.2	Added Electronic Commerce Center email address and government programs customer service phone numbers	May 15, 2017	1.2
Contact Information	4.1	Added contact information for government programs	May 15, 2017	1.2
Contact Information	4.2	Removed reference to Electronic Commerce Center; added language to direct provider to the appropriate vendor for EDI Technical Assistance	May 15, 2017	1.2
Contact Information	4.3	Adjusted wording (removed reference to claim status for commercial); also added government programs customer service phone numbers	May 15, 2017	1.2
Appendices	A1	Adjusted wording and removed reference to Electronic Options Tutorial	May 15, 2017	1.2
Appendices	A1	Removed hyperlink to Frequently Asked Questions document that was removed from the Provider website	April 9, 2018	1.3
Getting Started	2.2.2	Updated references to government programs product names and customer service phone number	April 9, 2018	1.3
Getting Started	2.3.2	Updated references to government programs product names and customer service phone number	April 9, 2018	1.3
Contact Information	4.1	Updated references to government programs product names and customer service phone number	April 9, 2018	1.3
Contact Information	4.3	Updated references to government programs product names and customer service phone number	April 9, 2018	1.3

CAQH CORE is a multi-stakeholder collaboration of more than 130 organizations representing providers, health plans, vendors, government agencies and standard-setting bodies developing operating rules to help simplify health care administrative transactions. For additional information, refer to the CORE section of the CAQH website at <http://www.cagh.org/benefits.php>.

Availity is a trademark of Availity, LLC, Availity is a separate company that operates a health information network to provide electronic information exchange services to medical professionals. Availity provides administrative services to BCBSTX. BCBSTX makes no endorsement, representations or warranties regarding any products or services offered by third party vendors such as Availity. If you have any questions about the products or services offered by such vendors, you should contact the vendors directly.

Blue Cross®, Blue Shield® and the Cross and Shield Symbols are registered service marks of the Blue Cross and Blue Shield Association, an association of independent Blue Cross and Blue Shield Plans.